



Modular Cooking Range Line 900XP One Well Electric Fryer 15 liter

ITEM # _____

MODEL # _____

NAME # _____

SIS # _____

AIA # _____



391087 (E9FRED1GF0)

15-lt electric fryer with 1 "V" shaped well (external heating elements) and 1 basket

Short Form Specification

Item No. _____

High efficiency infrared heating elements (10kW) attached to the outside of the well. Deep drawn V-Shaped well. Oil drains through a tap into a container positioned under the well. Height adjustable feet in stainless steel. Exterior panels in stainless steel. Worktop in 20/10, stainless steel. Right-angled side edges eliminate gaps and possible dirt traps between units.

Main Features

- Deep drawn V-Shaped well.
- External infrared heating elements for ease of cleaning of internal well.
- Thermostatic regulation of oil temperature up to a maximum of 185 °C.
- Overheat protection thermostat as standard on all units.
- Oil drains through a tap into a drainage container positioned under the well.
- All major compartments located in front of unit for ease of maintenance.
- The special design of the control knob system guarantees against water infiltration.
- Unit delivered with four 50 mm legs in stainless steel as standard (all round Stainless steel kick plates as option).
- Supplied as standard with 1 basket and 1 right side door for cupboard.
- Optional portable oil quality monitoring tool (code 9B8081) for efficient oil management.

Construction

- Unit is 930 mm deep to give a larger working surface area.
- All exterior panels in Stainless Steel with Scotch Brite finishing.
- Model has right-angled side edges to allow flush fitting joints between units, eliminating gaps and possible dirt traps.
- Interior of well with rounded corners for ease of cleaning.
- IPX5 water resistance certification.

Sustainability



- This model is compliant with Swiss Energy Efficiency Ordinance (730.02).

Included Accessories

- 1 of Door for open base cupboard PNC 206350
- 1 of 1 full size basket for 14/15lt fryers PNC 921691

Optional Accessories

- Junction sealing kit PNC 206086
- Flanged feet kit PNC 206136
- Support for bridge type system, 1600mm PNC 206141
- Frontal kicking strip for concrete installation, 400mm PNC 206147
- Frontal kicking strip for concrete installation, 800mm PNC 206148

APPROVAL: _____



- | | | | | | |
|--|------------|--------------------------|--|------------|--------------------------|
| • Frontal kicking strip for concrete installation, 1000mm | PNC 206150 | <input type="checkbox"/> | • Unclogging rod for 15lt drainage pipe | PNC 921695 | <input type="checkbox"/> |
| • Frontal kicking strip for concrete installation, 1200mm | PNC 206151 | <input type="checkbox"/> | • Deflector for floured products for 15lt fryers | PNC 921696 | <input type="checkbox"/> |
| • Frontal kicking strip for concrete installation, 1600mm | PNC 206152 | <input type="checkbox"/> | | | |
| • 2 SIDE KICKING STRIPS- CONCRETE INST-900 | PNC 206157 | <input type="checkbox"/> | | | |
| • Frontal kicking strip, 400mm (not for refr-freezer base) | PNC 206175 | <input type="checkbox"/> | | | |
| • Frontal kicking strip, 800mm (not for refr-freezer base) | PNC 206176 | <input type="checkbox"/> | | | |
| • Frontal kicking strip, 1000mm (not for refr-freezer base) | PNC 206177 | <input type="checkbox"/> | | | |
| • Frontal kicking strip, 1200mm (not for refr-freezer base) | PNC 206178 | <input type="checkbox"/> | | | |
| • Frontal kicking strip, 1600mm (not for refr-freezer base) | PNC 206179 | <input type="checkbox"/> | | | |
| • Pair of side kicking strips (not for refr-freezer base) | PNC 206180 | <input type="checkbox"/> | | | |
| • 2 panels for service duct for single installation | PNC 206181 | <input type="checkbox"/> | | | |
| • 2 panels for service duct for back to back installation | PNC 206202 | <input type="checkbox"/> | | | |
| • 4 feet for concrete installation | PNC 206210 | <input type="checkbox"/> | | | |
| • Sediment tray for 15lt fryers | PNC 206235 | <input type="checkbox"/> | | | |
| • Oil drain pipe for 15lt free standing fryer | PNC 206301 | <input type="checkbox"/> | | | |
| • Chimney upstand, 400mm | PNC 206303 | <input type="checkbox"/> | | | |
| • BACK HANDRAIL 800 MM - MARINE | PNC 206308 | <input type="checkbox"/> | | | |
| • BACK HANDRAIL 1200 MM - MARINE | PNC 206309 | <input type="checkbox"/> | | | |
| • Door for open base cupboard | PNC 206350 | <input type="checkbox"/> | | | |
| • Base support for feet or wheels - 400mm (700/900XP) | PNC 206366 | <input type="checkbox"/> | | | |
| • Base support for feet or wheels - 800mm (700/900) | PNC 206367 | <input type="checkbox"/> | | | |
| • Base support for feet or wheels - 1200mm (700/900) | PNC 206368 | <input type="checkbox"/> | | | |
| • Base support for feet or wheels - 1600mm (700/900) | PNC 206369 | <input type="checkbox"/> | | | |
| • Base support for feet or wheels - 2000mm (700/900) | PNC 206370 | <input type="checkbox"/> | | | |
| • Rear paneling - 600mm (700/900XP) | PNC 206373 | <input type="checkbox"/> | | | |
| • Rear paneling - 800mm (700/900) | PNC 206374 | <input type="checkbox"/> | | | |
| • Rear paneling - 1000mm (700/900) | PNC 206375 | <input type="checkbox"/> | | | |
| • Rear paneling - 1200mm (700/900) | PNC 206376 | <input type="checkbox"/> | | | |
| • Chimney grid net, 400mm | PNC 206400 | <input type="checkbox"/> | | | |
| • BASE SUPPORT FOR FEET/WHEELS 600M | PNC 206431 | <input type="checkbox"/> | | | |
| • 2 side covering panels for free standing appliances | PNC 216134 | <input type="checkbox"/> | | | |
| • 1 full size basket for 14/15lt fryers | PNC 921691 | <input type="checkbox"/> | | | |
| • 2 half size baskets for 14/15lt fryers | PNC 921692 | <input type="checkbox"/> | | | |
| • Filter for fryer oil collection basin for 7lt, 14lt, 15lt free standing fryers | PNC 921693 | <input type="checkbox"/> | | | |

Front

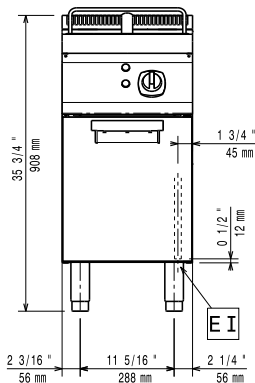

Side

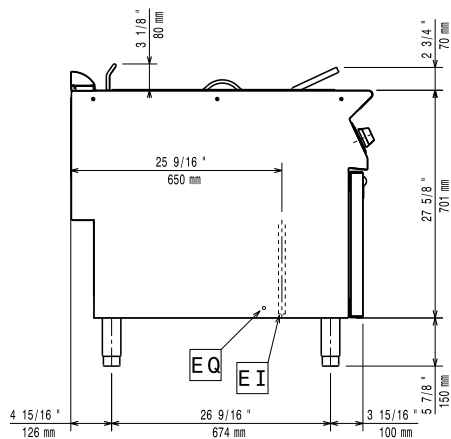

EI = Electrical inlet (power)
 EQ = Equipotential screw

Top

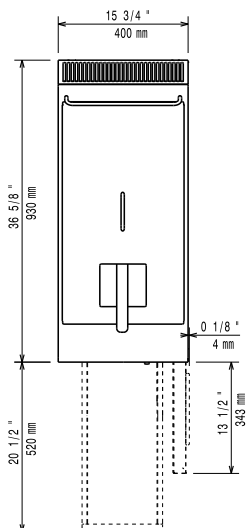

Electric

Supply voltage:	380-400 V/3N ph/50-60 Hz
Total Watts:	10 kW

Key Information:

Usable well dimensions (width):	240 mm
Usable well dimensions (height):	505 mm
Usable well dimensions (depth):	380 mm
Well capacity:	13 lt MIN; 15 lt MAX
Thermostat Range:	105 °C MIN; 185 °C MAX
Net weight:	50 kg
Shipping weight:	59 kg
Shipping height:	1080 mm
Shipping width:	460 mm
Shipping depth:	1020 mm
Shipping volume:	0.51 m ³
Certification group:	EFE91M15

If appliance is set up or next to or against temperature sensitive furniture or similar, a safety gap of approximately 150 mm should be maintained or some form of heat insulation fitted.